

**PLUS** Größen • Tailles • Sizes  
 Eur.: **36 - 54**  
 US: **10 - 28**

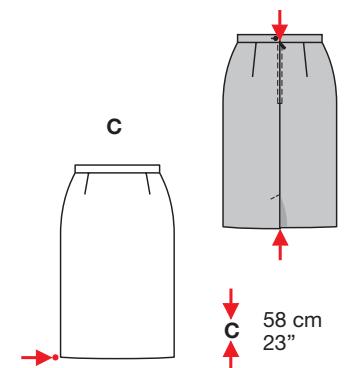
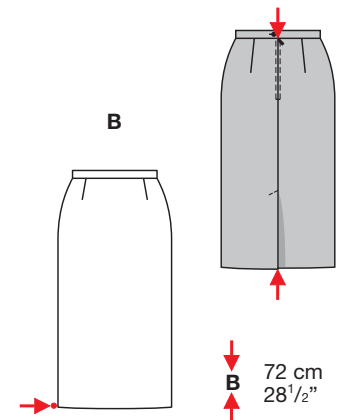
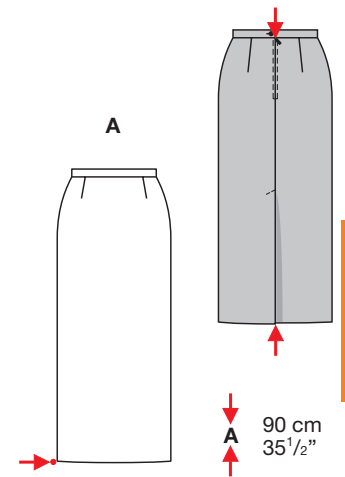

**ABC** 94 - 138 cm  
 37" to 54 1/2"

## ROCK • JUPE • SKIRT • FALDA

Größen Tailles • Sizes	Eur. US	114 cm / 45 ins								140 cm / 55 ins																								
		36	40	42	44	46	48	50	52	54	36	40	42	44	46	48	50	52	54															
A	m	1.60	1.60	1.95	1.95	1.95	1.95	1.95	1.95	1.10	1.10	1.10	1.10	1.10	1.60	1.95	1.95	yds	1 3/4	1 3/4	2 1/4	2 1/4	2 1/4	2 1/4	2 1/4	2 1/4	1 1/4	1 1/4	1 1/4	1 1/4	1 1/4	2 1/4	2 1/4	
A Futter • Doublure Lining	m	0.95	0.95	0.95	1.65	1.90	1.90	1.90	1.90	0.95	0.95	0.95	0.95	0.95	0.95	1.65	1.70	yds	1 1/8	1 1/8	1 1/8	1 1/8	2 1/8	2 1/8	2 1/8	2 1/8	1 1/8	1 1/8	1 1/8	1 1/8	1 1/8	1 1/8	1 1/8	1 1/8
B	m	1.25	1.25	1.60	1.60	1.60	1.60	1.60	1.60	0.90	0.90	0.90	0.90	0.90	1.25	1.60	1.60	yds	1 1/2	1 1/2	1 3/4	1 3/4	1 3/4	1 3/4	1 3/4	1 3/4	1	1	1	1	1	1 1/2	1 3/4	1 3/4
B Futter • Doublure Lining	m	0.80	0.80	0.80	1.35	1.55	1.55	1.55	1.55	0.80	0.80	0.80	0.80	0.80	0.80	1.30	1.40	yds	7/8	7/8	7/8	1 3/8	1 5/8	1 5/8	1 5/8	1 5/8	7/8	7/8	7/8	7/8	7/8	7/8	1 1/2	1 5/8
C	m	0.95	0.95	1.35	1.35	1.35	1.35	1.35	1.35	0.75	0.75	0.75	0.75	0.75	0.95	1.35	1.35	yds	1 1/8	1 1/8	1 5/8	1 5/8	1 5/8	1 5/8	1 5/8	1 5/8	7/8	7/8	7/8	7/8	7/8	1 1/8	1 5/8	1 5/8
C Futter • Doublure Lining	m	0.65	0.65	0.65	1.05	1.30	1.30	1.30	1.30	0.65	0.65	0.65	0.65	0.65	0.65	0.95	1.10	yds	7/8	7/8	7/8	1 1/4	1 1/2	1 1/2	1 1/2	1 1/2	7/8	7/8	7/8	7/8	7/8	7/8	1 1/8	1 1/4



leicht, facile, easy, fácil.

**ABC:** eng anliegend, très ajusté, close fitting.

**Stoffempfehlung:**

Flanell, Tweed, Leinen.

**Tissus conseillés:**

flanelle, tweed, lin.

**Recommended fabrics:**

flannel, tweed, linen.

**ACHTUNG!** Bei kariertem Stoff erhöhter Stoffverbrauch.

**ATTENTION!** Pour les tissus à carreaux compter un métrage supérieur.

**IMPORTANT!** extra fabric required to match plaids.

→ mit Richtung • avec sens • with nap

**8765**